



HAPPIJAC[®]

by  Lippert Components[®]

HAPPIJAC[®] BED LIFT OWNER'S MANUAL

TABLE OF CONTENTS

Introduction	2
Safety	3
Product Component Descriptions	4
Frame.....	4
Brackets.....	5
Limit Switches.....	5
Bunk Stop Settings.....	6
Operating Precautions	7
Operation	7
Control Switch.....	7
Upper Trolleys.....	8
Lower Trolley: Sofa or Dinette Configuration.....	9
Adjustments	10
Upper Trolley Tab Rotation.....	10
Lower Trolley Sofa/Dinette Bracket Removal.....	11
Lower Bunk Trolley Tab Installation.....	12
Maintenance	13
Troubleshooting	13
Emergency Manual Operation	14
Manually Raise the Bed(s)/Sofa or Dinettes.....	14
Manually Lowering the Bed(s).....	15

Introduction

The HappiJac® Bed Lift System is a chain-driven two trolley lift system operated by a 12V DC motor, which can be installed in most toy hauler trailers. It can accommodate one or two beds, or an alternate of a bed and a dinette/sofa configuration.

This product is designed and intended to be used only as a bed lift mechanism. Any other use of this system will void any and all written or expressed warranties.

NOTE: These ratings are for the lifting mechanism only. HappiJac does not manufacture and therefore does not rate any attachments, such as bed platforms, sofas, etc. Load ratings for these items would be the responsibility of the manufacturer.

Voltage = 12V DC

Nominal Current Draw = 8 amps (1 bed going up)
12 amps (2 beds or 1 bed and 1 sofa/dinette configuration going up)

Load Limit = 450 pounds dynamic (moving) load
500 pounds static (stationary) load

Safety

This manual provides general instructions. Many variables can change the circumstances of the instructions, i.e., the degree of difficulty, operation and ability of the individual performing the instructions. This manual cannot begin to plot out instructions for every possibility, but provides the general instructions, as necessary, for effectively interfacing with the device, product or system. Failure to correctly follow the provided instructions may result in death, serious personal injury, severe product and/or property damage, including voiding of the LCI limited warranty.

WARNING

The "WARNING" symbol above is a sign that a procedure has a safety risk involved and may cause death or serious personal injury if not performed safely and within the parameters set forth in this manual.

WARNING

Failure to follow instructions provided in this manual may result in death, serious personal injury and/or severe product and property damage, including voiding of the component warranty.

CAUTION

The "CAUTION" symbol above is a sign that a procedure has a safety risk involved that may cause personal injury and/or product damage, including voiding of warranty, if not performed safely and in accordance with the safety procedures stated herein.

CAUTION

Always wear eye protection when performing service, maintenance procedures. Other safety equipment to consider would be hearing protection, gloves and possibly a full face shield, depending on the nature of the task.

CAUTION

Moving parts can pinch, crush or cut. Keep clear and use caution.

Product Component Descriptions

Frame

The lift system frame has four vertical c-channel rails (Fig. 1A). Each c-channel rail encases a chain drive and two trolleys (Fig. 2) with attached brackets that travel between upper and lower limit switches.

Fig. 1

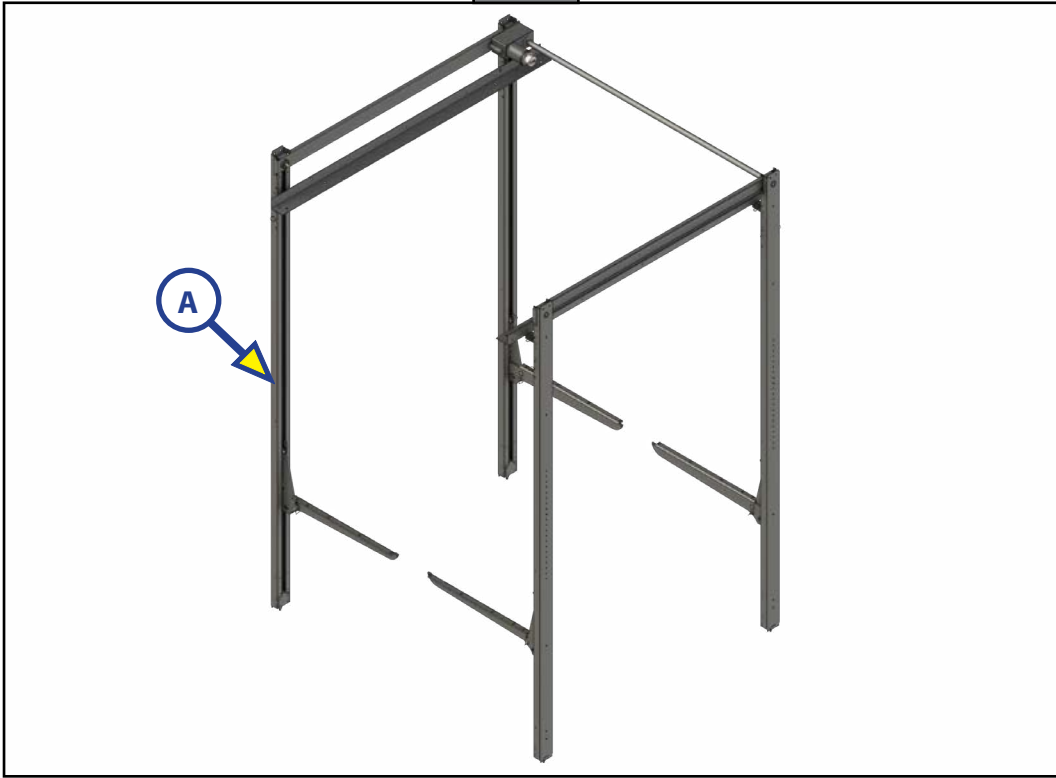
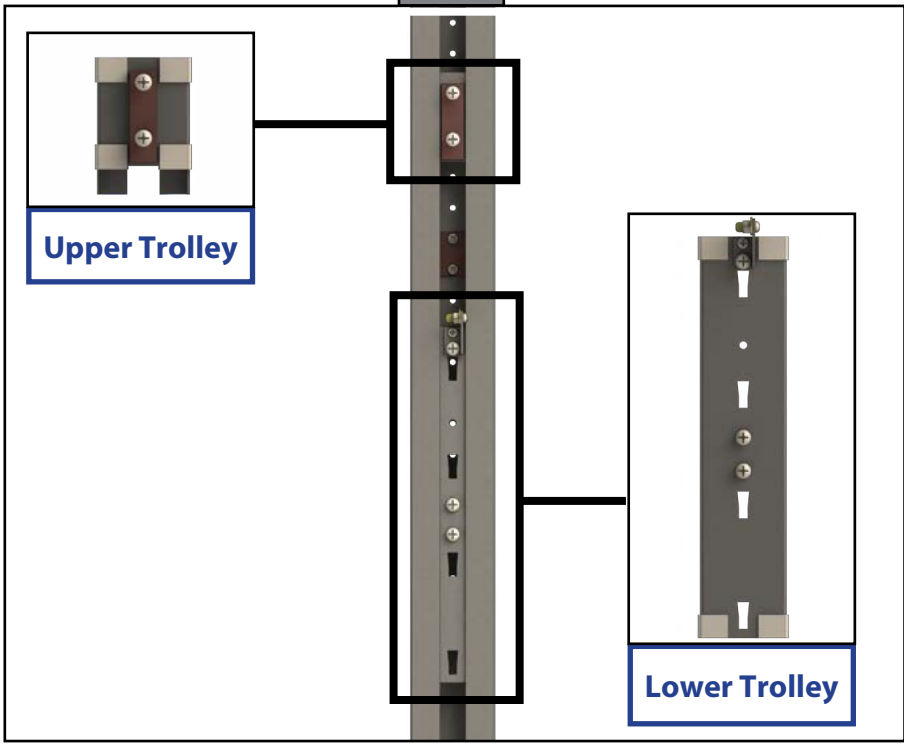

Fig. 2



Brackets

The HappiJac Bedlift system comes installed with screw-in tab brackets (Fig. 3) affixed to the upper trolleys. The lower trolleys can be fitted with hooked tab brackets (Fig. 4) for a lower bed platform, or hooked brackets with moveable arms (Fig. 5) that can accommodate a sofa/dinette configuration.

Fig. 3



Fig. 4



Fig. 5



Limit Switches

Upper and lower limit switches (Fig. 6A) are located behind the C-channel and secured by two small screws (Fig. 5B). The limit switches are used to stop the bed(s) at their maximum travel range. However, the bed(s) can be stopped and used at any desired height. After the control switch is released, the electric brake is set — securing the bed(s) in the current position.

Fig. 6

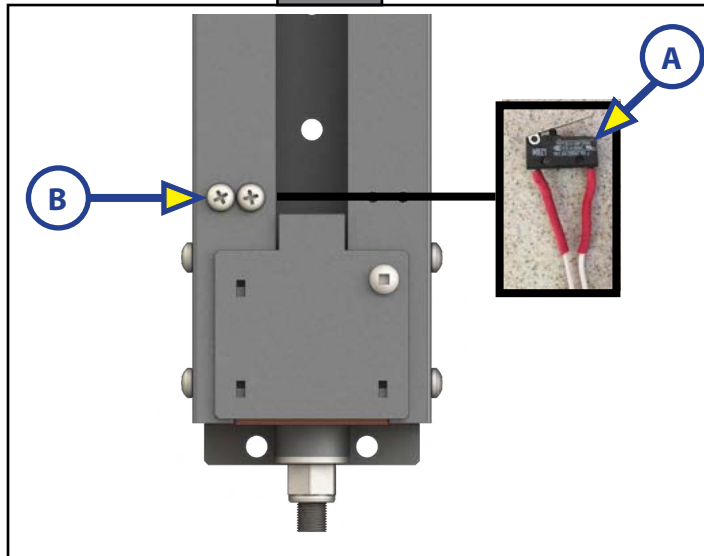

Bunk Stop Settings

The upper bunk trolley is free-floating and is carried by the lower trolley. The height at which this trolley stops is set by "stop blocks" which sit inside the trolley rails. To change this stop, remove the two screws holding the bed in place, and move it to the desired height (Fig. 7). Repeat for all four corners.

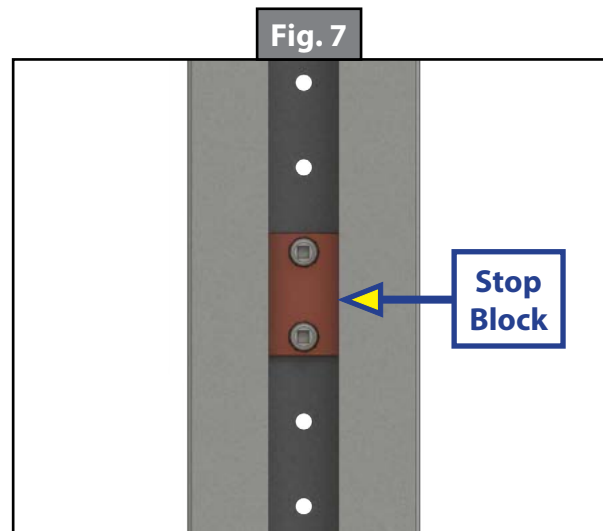

Operating Precautions

- **CHECK** to make sure the attaching pins are securely fastened to all four corners of the bed platform before towing the trailer, or using the bed(s).
- **ALWAYS** raise the bed(s) to the full up position when the trailer is being towed to avoid damage to the bed lift system as a result of bouncing.
- **ALWAYS** make sure that the areas above, below and adjacent to the bed(s) are free from obstructions before operating the bed(s).
- **ALWAYS** check before operating bed(s) to ensure that there is nothing interfering with the travel of the chain mechanism inside the c-channel.
- **ALWAYS** use care when loading cargo/vehicles in the bed area. This is to avoid damage to the bed mechanism.
- **ALWAYS** properly secure loads in the bed area to avoid damage to the bed mechanism from shifting or falling loads.
- **NEVER** operate the bed(s) with any items other than bedding on the bed platform(s).
- **NEVER** travel with any items other than bedding on the bed(s). Loose items can become projectiles.
- **NEVER** operate the bed(s) when persons or pets are on the bed platform.
- **NEVER** hang from, or hang more than 20 pounds, on the cross-connecting shaft.

Operation

Control Switch

NOTE: Upper and lower trolleys move together, unless one trolley set has been locked into place.

The the upper and lower trolleys are operated from the control switch (Fig 8). Pressing and holding the switch in the UP position (Fig. 7A) moves the trolleys upward. Pressing and holding the switch in the DOWN position (Fig. 7B) moves the trolleys downward.

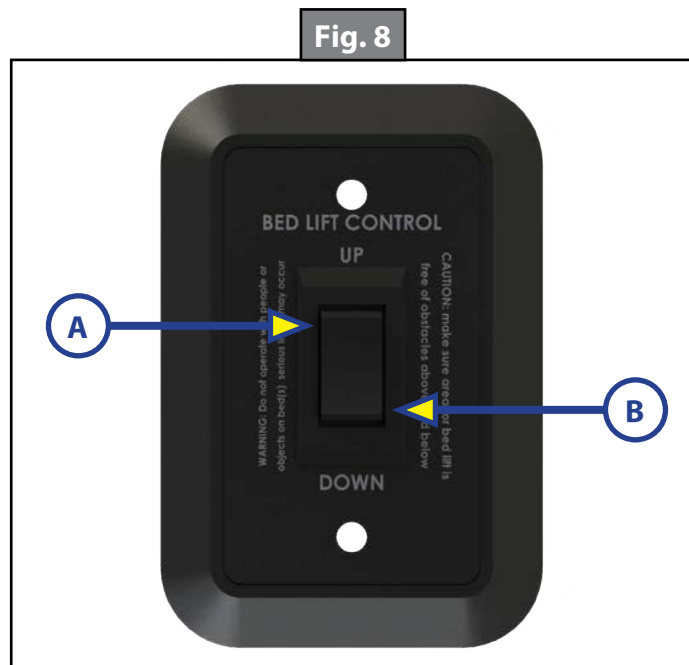

⚠ CAUTION

The upper trolleys can drift down if not properly secured. Make sure that the securing pins are in place after adjusting the upper trolleys.

The upper trolleys are only used to support a bed platform. Bed platform rails (Fig. 9A) are secured to the tab brackets (Fig 9B) and the bed platform rests on the platform rails.

Lowering

1. Put the sofa or dinette seats, if equipped, in the up (stowed) position. (See Lower Trolley: Sofa or Dinette Configuration.)

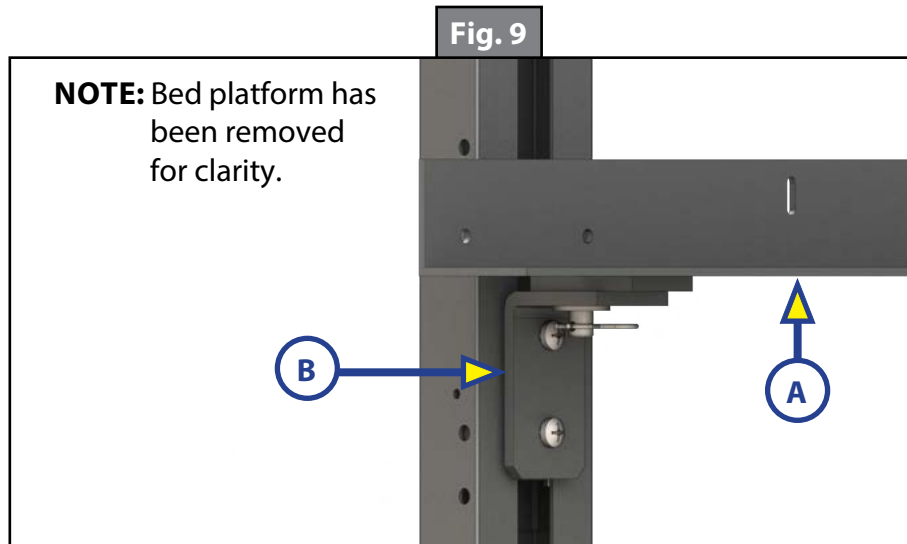

2. Pull the all four pins (Fig. 10A) securing the upper trolleys (Fig. 10B) to the C-channel rails (Fig. 10C).

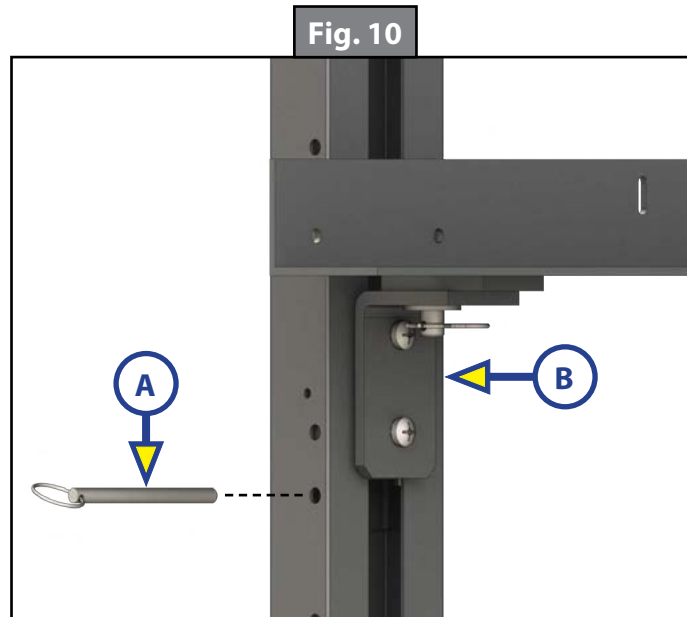

3. Press the DOWN switch and the upper and lower trolleys will come down together. The upper trolleys will stop at the first bunk stop block.
4. The the lower trolleys can continue to lower.
5. Replace the pins securing the top bunk.

Stowing

The HappiJac Bed Lift system has a stow feature for the upper trolley, where the upper limit switches stop the upper trolleys in uppermost position to provide maximum space underneath the bed platform attached to the upper trolleys.

NOTE: Lower trolleys can still move up and down when the upper trolleys are in the stowed position.

1. Press the UP switch to run the upper trolleys until they are stopped by the upper limit switches.
2. Insert all four locking pins (Fig. 10A) through the C-channel rails.
3. Lower bottom bunk to desired operational height.

To Un-stow

1. Retract the beds up to the up and retracted position.
2. Remove all four locking pins (Fig. 10A) from the C-channel rails.
3. Lower both platforms until the top bunk rests on the bunk stops, and the lower platform continues to extend and lower to the desired operational height.

Lower Trolley: Sofa or Dinette Configuration

The lift system can be configured to accommodate a bed on the upper trolley and a sofa or dinette on the lower trolleys. The sofa or dinette will need extra brackets that will lock into the lower trolleys.

NOTE: Bracket shown without sofa or dinette attached. Consult the manufacturer's instructions for bracket installation on sofa or dinette units.

Lowering the Arm

1. Remove the lockpins securing both bracket arms (Fig. 11A).
2. Pull up slightly on the bracket arm (sofa or dinette seat base) (Fig. 11B), then pull out.
3. Gently lower the arm (sofa or dinette seat base).

Fig. 11

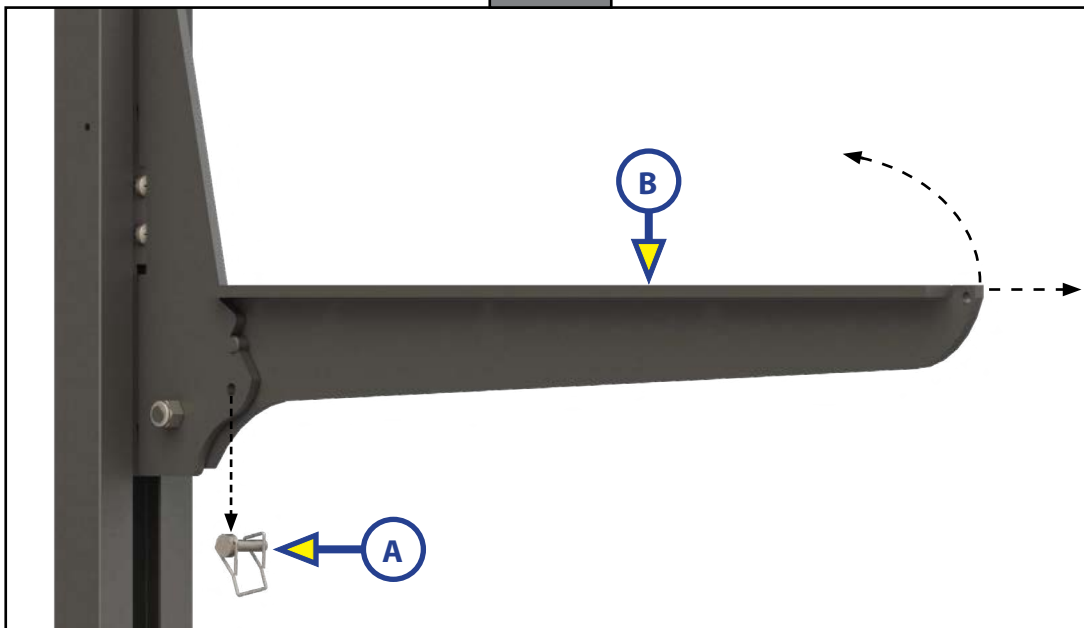

Lower Trolley Stop Lock

Each of the lower trolleys has a stop lock to keep the lower trolleys from travelling upwards. To engage the stop lock, flip the long end of stop lock lever (Fig. 12A) towards the inside of the C-channel rail. This lever will now catch on the bottom edge of the stop blocks in the C-channel rail, stopping the upward progress.

To disengage: pull the short end (Fig. 13) of the stop lock lever down to flip the long end out of the C-channel rail.

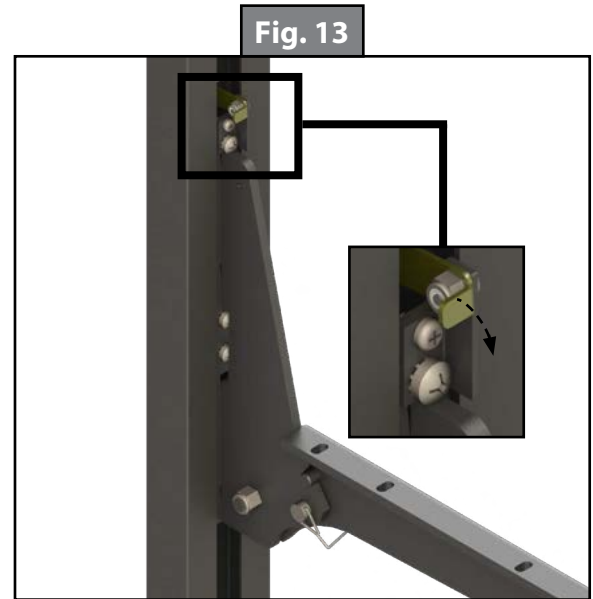
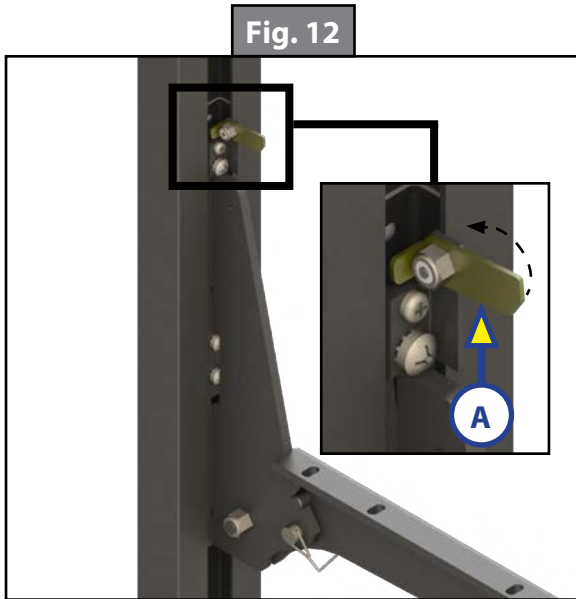

Adjustments

Upper Trolley Tab Rotation

The upper trolley tabs can be rotated to change the amount of space between the bed platform and the upper bunk stop.

1. Remove the bed platform.
2. Remove the adjustment pins and lower the bedlift so there is enough clearance to remove the bedrail without hitting the motor
3. Replace the adjustment pin.
4. Remove the hairpin (Fig. 14A) securing the clevis pin (Fig. 14B) and washer (Fig. 14C).
5. Remove the clevis pin holding the bedlift rail (Fig. 14D) to the tab bracket (Fig. 14E).

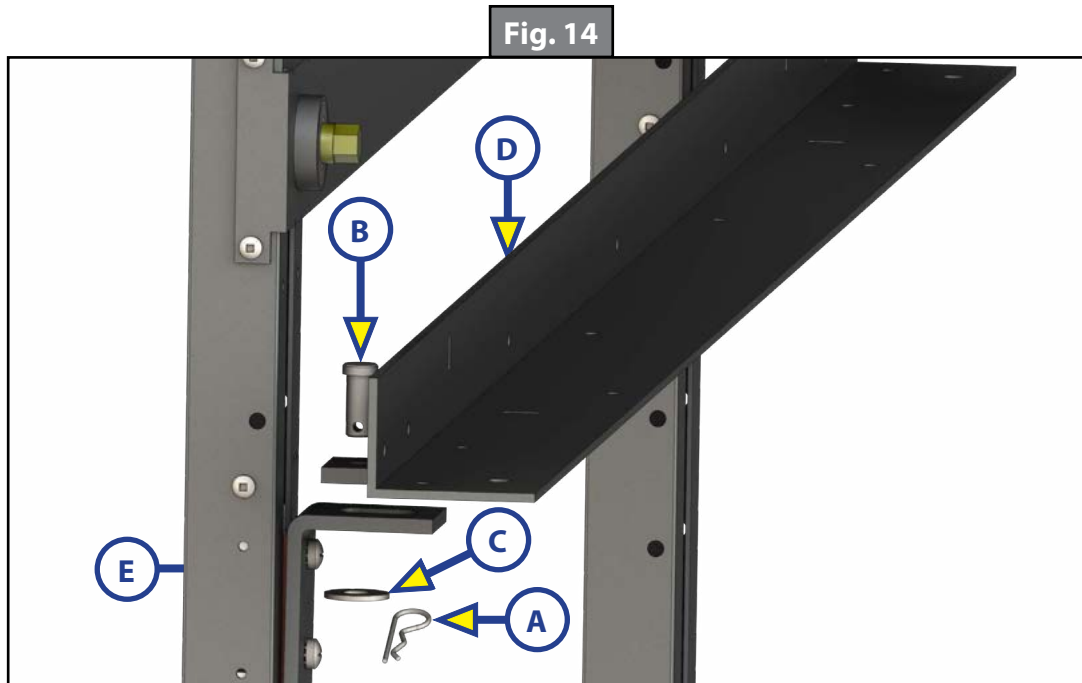

6. Repeat for the other side.
7. Lift the bedrail rail off of the tab brackets and set aside.
8. Remove the screws (Fig. 15A) securing the tab bracket (Fig. 15B) to travel block (Fig. 15C), then flip the tab bracket 180 degrees.

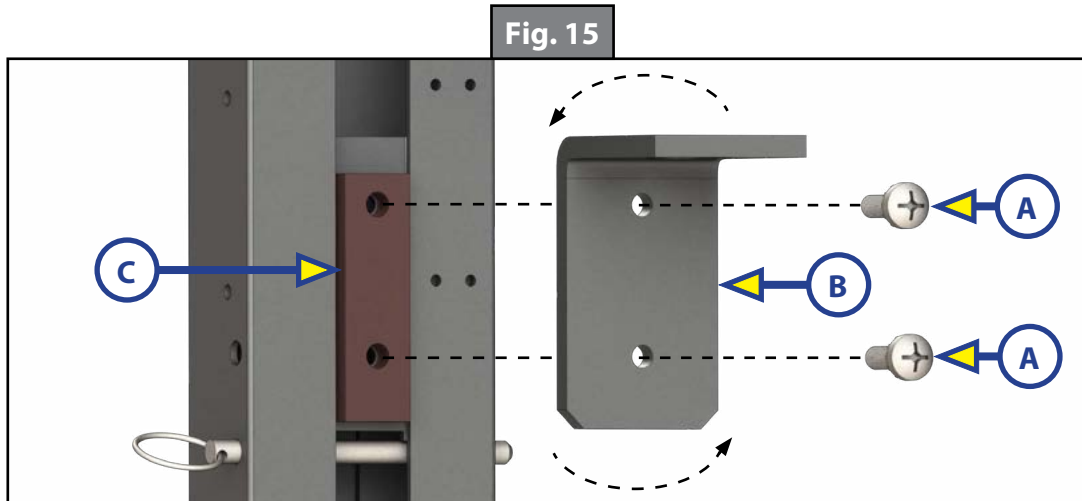

9. Re-attach the tab to the travel block.
10. Repeat for the other tab brackets.
11. Place the bedlift rail on the trolley tabs.
12. Secure the bedlift rail to the trolley tabs with the clevis pins and cotter (hair) pins.
13. Repeat steps 11 and 12 for the other side.
14. Replace the bed platform.

Lower Trolley Sofa/Dinette Bracket Removal

The sofa/dinette brackets can be removed from the lower trolleys and trolley tabs can be added to accommodate a second bed platform. See Lower Bunk Trolley Tab Installation for instructions on adding trolley tabs.

1. Remove the sofa/dinette configuration or bed platform from the support brackets.
2. Remove the locking pin (Fig. 16A) from the bracket, then lower the bracket arm (Fig 16B).

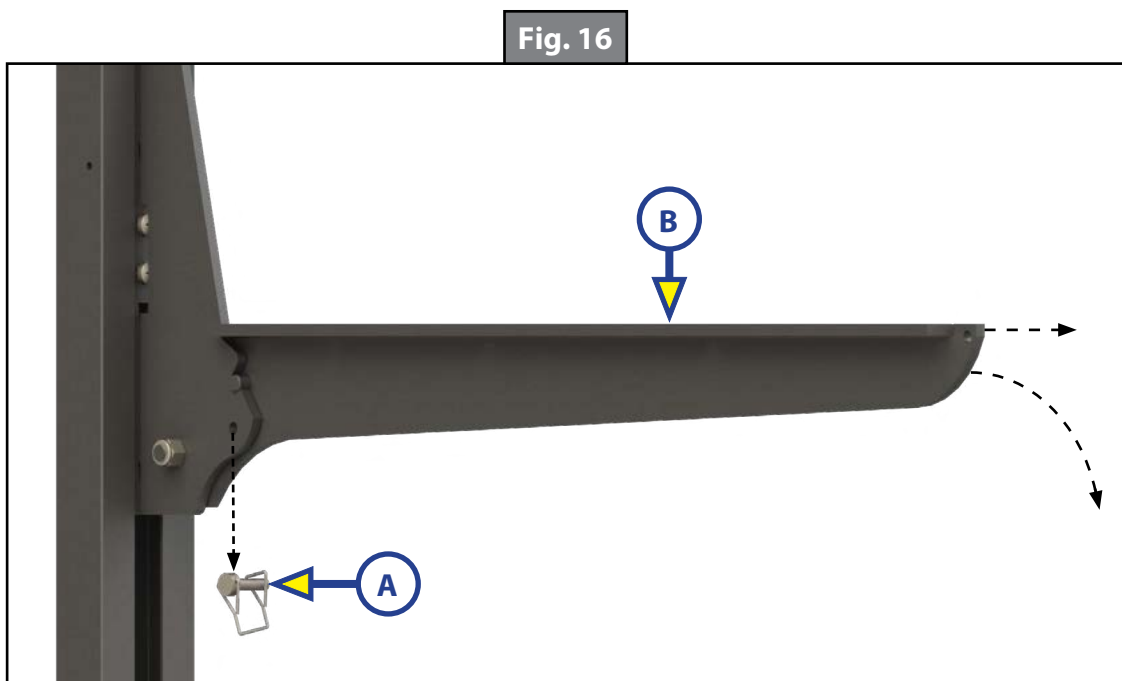

3. Remove the stop screw (Fig. 17A) from securing the support bracket, then remove the screw (Fig 17B) securing the trolley stop lock bracket (Fig. 17C) and remove the bracket.
4. Grasp the base of the sofa bracket (Fig. 18A) and pull up until the hooks are even with travel trolley slots (Fig. 18B), then pull the sofa bracket away from the travel trolley.
5. Repeat for other brackets.

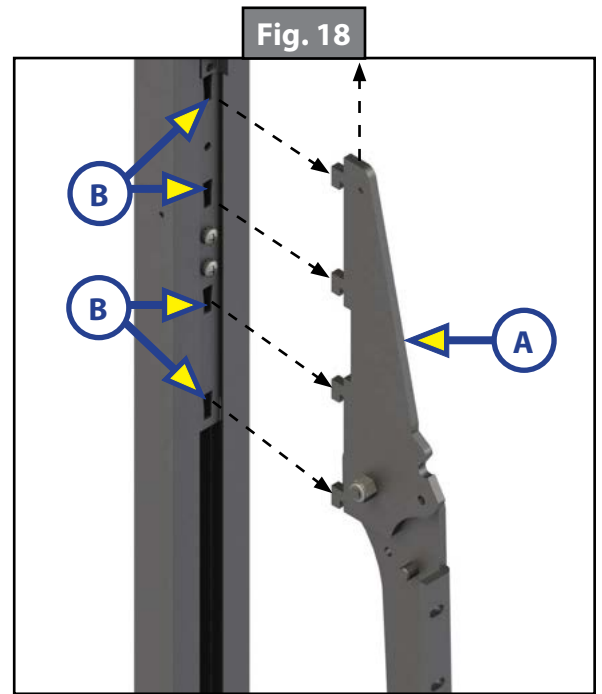
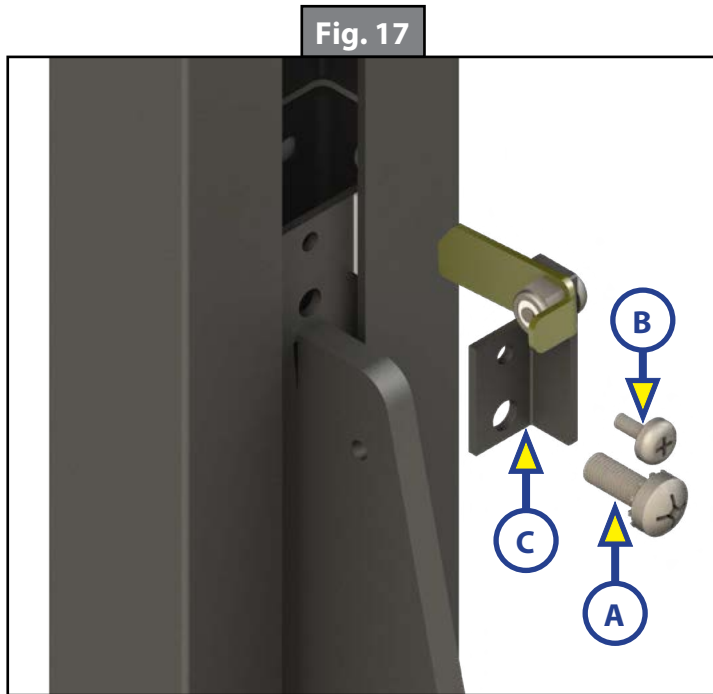

Lower Bunk Trolley Tab Installation

Trolley tabs can be added to the lower trolleys to accommodate a bed platform, after the sofa/dinette brackets have been removed.

NOTE: There are four slots in the lower trolley. This trolley tab can go in either the top two or bottom two slots. The bracket can only be installed with the trolley tab at the top.

1. Remove the sofa brackets from the lower travel trolley. See Lower Trolley Sofa/Dinette Bracket Removal.
2. Line up the hooks on the edge of the trolley tab bracket (Fig. 19A) with the channels (Fig. 19B) in the travel trolley, then push the brackets into the channels.

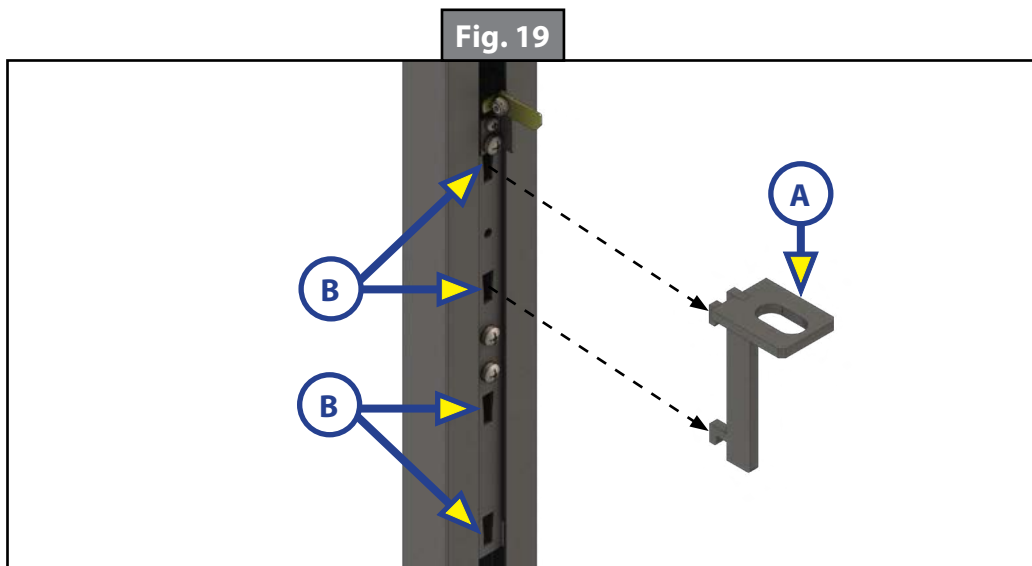

3. Push the bracket down so it locks into the trolley tab channels.
4. Repeat for other trolley tabs.

Maintenance

The bed lift system requires very little maintenance. The chains are pre-lubricated and nickel-plated to prevent corrosion. All bearings are sealed and all parts are either plated or finished with a durable powder-coat finish.

The only required maintenance involves keeping the mechanisms clean and free of debris. When cleaning the trailer after use, inspect the vertical trolley channels for dirt or debris and clean as necessary. After cleaning, a light application of dry silicone spray on the inner sides of the trolley channels will improve performance and reduce noise and required amperage draw.

Troubleshooting

What Is Happening?	Why?	What Should Be Done?
Bed(s) will not move either up or down when switch is pressed.	No or insufficient power to operate the bed(s).	Make certain trailer batteries are adequately charged, connect to shore power or a generator.
	Faulty control module.	Replace module.
	Faulty UP/DOWN switch.	Replace switch.
	Defective motor.	Contact LCI Customer Service.
Bed travels in only one direction.	Defective limit switch.	Replace switch.
	Faulty control module.	Replace module.
	Faulty UP/DOWN switch.	Replace switch.
	Faulty brake.	Set manual brake release lever on motor to the "OFF" position. If the bed(s) move, replace the faulty brake.
Bed lowers, but stops part way going up.	Insufficient power to bed.	Make certain trailer batteries are adequately charged, connect to shore power or a generator.
	Defective motor/brake assembly.	Contact LCI Customer Service.
Bed does not stay level; side-to-side or front-to-back.	Broken or loose timing shaft.	Contact LCI Customer Service.
	Broken chain sprocket.	Contact LCI Customer Service.
When lowered, bed fails to stop at preset stop point.	Motor brake not engaging.	Contact LCI Customer Service.
	Defective limit switch.	Replace switch.
When raised, bed fails to stop at preset stop point.	Defect or damaged limit switch.	Replace switch.
Upper bunk (two-bed system) does not lower smoothly.	Sticky bed carrier.	Spray a small amount of dry silicone lubricant into the rails.

Motor failures are extremely rare and motors are expensive. If uncertain of failure, contact LCI customer service at customerservice@lci1.com or (574) 547-8900 before replacing the motor.

Emergency Manual Operation

Before releasing the brake in manual mode, make sure there are no obstacles below the bed(s), sofa or dinette. Be prepared to apply the brake, if necessary, and make sure to move the brake back into the ON position once the desired height is reached.

⚠ CAUTION

When bed(s)/are not being manually raised or lowered, the brake **MUST** be set or the bed(s) will drift down, causing possible personal injury, product or property damage.

Manually Raise the Bed(s)/Sofa or Dinettes

Do the following in the order listed:

1. Unplug the motor harness from the motor port (Fig. 20A) on the PnP control module.

NOTE: The PnP control module could be mounted in other locations close to the motor.

Fig. 20



2. Release the brake by pushing up on the brake release (Fig. 21A).

Fig. 21

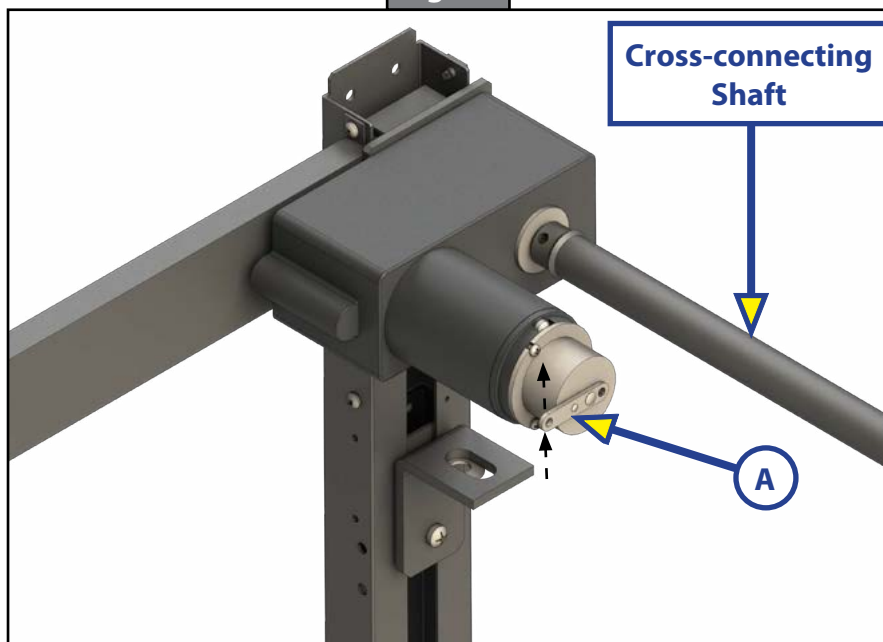

3. Remove the caps from the cranking points, which are located at the top of the front c-channels (opposite of the c-channels where the motor and cross-connecting shaft are installed).
4. Using a 1/2" socket and ratchet, manually crank the bed lift (Fig. 22).

NOTE: Cranking is easier if two people crank simultaneously, one on each side of the bed lift.

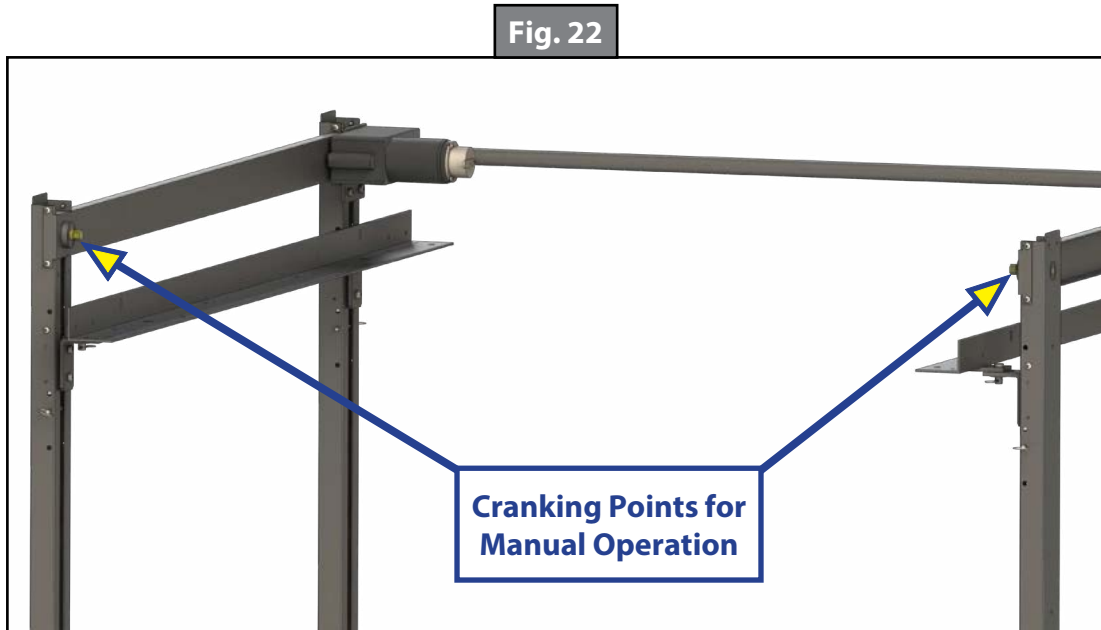

5. Apply brake at the desired bed height, then raise the brake release handle.
6. Reconnect the motor harness.

Manually Lowering the Bed(s)

Do as follows:

1. Unplug the motor harness from the PnP control module (Fig. 20).

CAUTION

Before releasing the brake in manual mode, make sure there are no people, pets or obstacles below the bed platforms. Keep hold of the brake lever as the bed(s) extends. Be prepared to apply the brake if necessary.

2. Push up on the brake release (Fig. 21A). Bed will drift downward.
3. Re-apply the brake by lowering the brake release handle when the desired bed height is reached.
4. Reconnect the motor harness.



L I P P E R T C O M P O N E N T S[®]

The contents of this manual are proprietary and copyright protected by Lippert Components, Inc. ("LCI"). LCI prohibits the copying or dissemination of portions of this manual unless prior written consent from an authorized LCI representative has been provided. Any unauthorized use shall void any applicable warranty. The information contained in this manual is subject to change without notice and at the sole discretion of LCI.

Revised editions are available for free download from lci1.com.

Please recycle all obsolete materials.

For all concerns or questions, please contact
Lippert Components, Inc.

Ph: (574) 537-8900 | Web: lci1.com | Email: customerservice@lci1.com